

Application Data Sheet



Pneumat Systems Europe, Ltd.

Customer Information

Company Name		Contact Person	
Address		Telephone	
City	Postal Code	Fax No.	Date

Silo Information

Dimensions

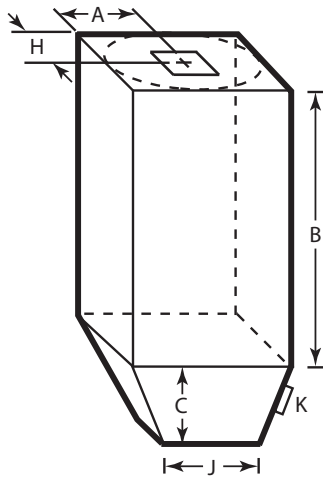

SILO TOP

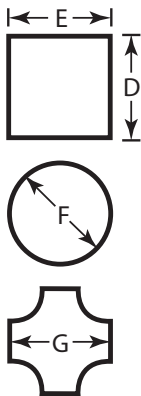

Please specify each dimension that applies to your silo and indicate unit of measure for each as:

Ft = feet cm = centimeters
In = inches m = meters.

- A _____
- B _____
- C _____
- D _____
- E _____
- F _____
- G _____
- H _____
- J _____
- K _____

Yes No

Is there an elevator or a hoist to the top of the silo? Yes No

Are there explosion-proof lights available? Yes No

Are there explosion-proof outlets? Yes No

Are there instruments in the silo? Yes No

Is there a dust collection system? Yes No

Obstructions (above or below)
Describe (within 50 cm any direction) Yes No

Manhole Opening:

Square Round Rect
_____ cm x _____ cm
Depth: _____ cm

Silo Construction:

Concrete
Steel
Other
Silo Identification N° _____

Silo Top: Indoors Outdoors

Electrical Supply:

380 V 3Ph Yes No
415 V 3Ph Yes No

Silo Condition

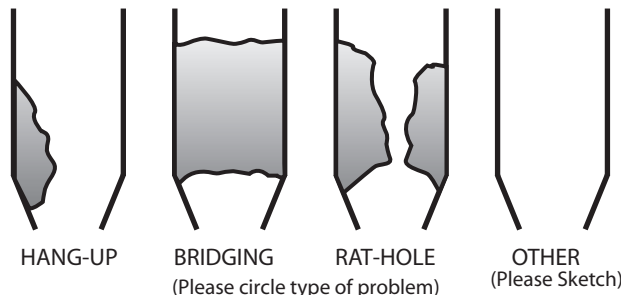

Description of Material _____
Quantity (Approximately) _____
Duration of clog _____
Hazardous? YES NO

Notes

Please briefly explain your situation or include any details not covered above

Fax or mail this questionnaire to:

Pneumat Systems Europe, Ltd.
22 Bold Business Centre • Bold Lane
Sutton • St. Helens • WA9 4TX • UK
Tel.: (44) (0)1925 290080 - Fax: (44) (0)1925 290085